

NOSE ASSEMBLY DATA SHEET

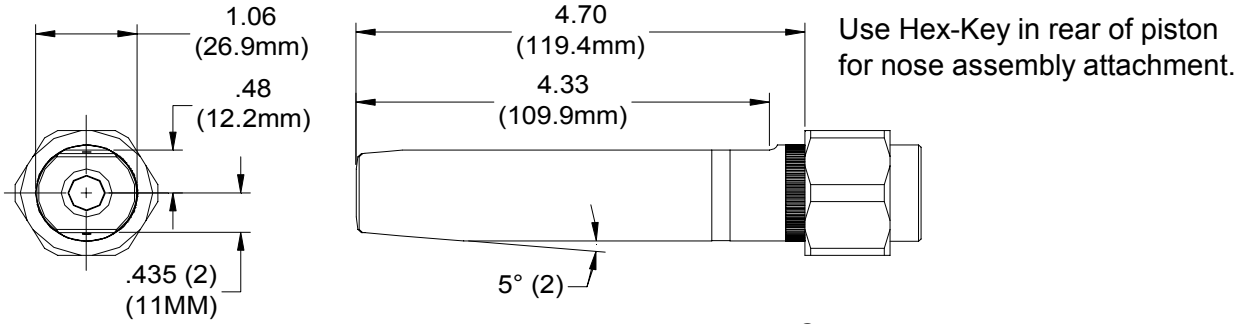

Slots on retaining nut stop, supplied with tool, fit over ears on anvil assembly

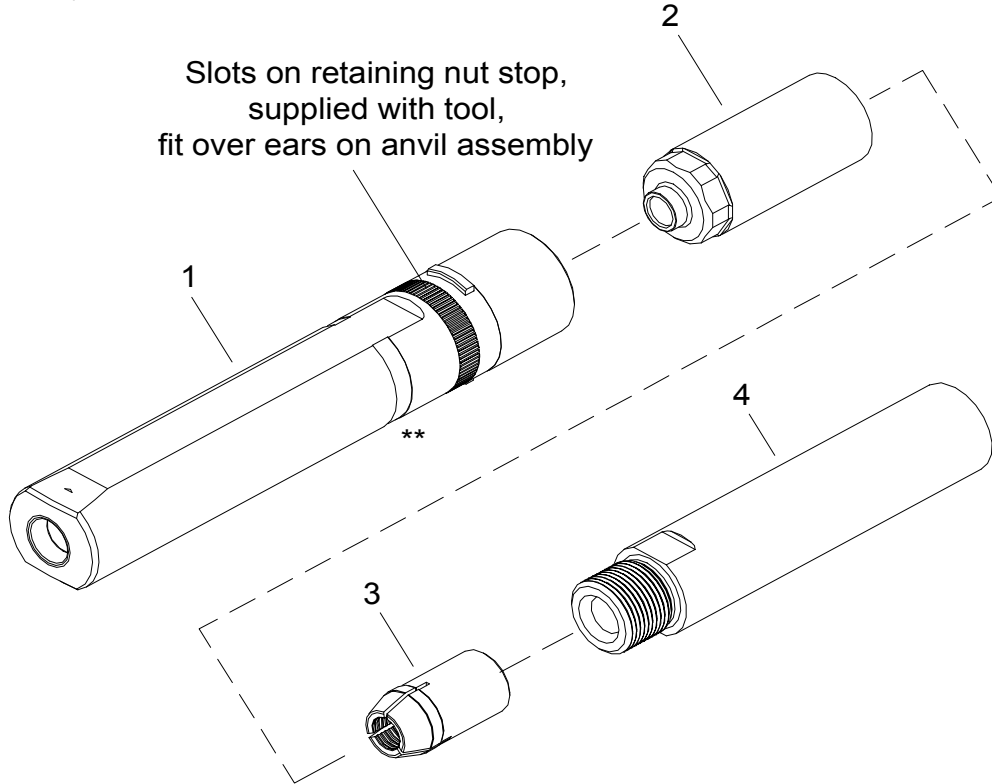

9/08



*Anvil Assembly includes 35308 retainer.
**Yellow band designates nose assemblies for lightweight GP® fasteners

GAGE BILT
MADE IN U.S.A.

GAGE BILT Inc.

44766 Centre Court (586) 286-1500
Clinton Twp., MI 48038 (586) 286-1505 Fax
e-mail: solutions@gagebilt.com / www.gagebilt.com

Type:		Fasteners:	Recommended Tool: GB745 (LGP10) GB756 (LGP12)	
Non Self-Releasing 5/16 & 3/8 Ø		LGP® lockbolts	Alternate Tools: GBP4801B	
Ref. No.	Qty.	Description	LGP10-756-48CN	LGP12-756-48CN
1	1	Anvil	11061-1	11225-1
2	1	Collet	21042	21225
3	1	Super-Grip Jaw Assembly	31028-S	31226-S
4	1	Collet Extension	71220	71220