

NOSE ASSEMBLY DATA SHEET

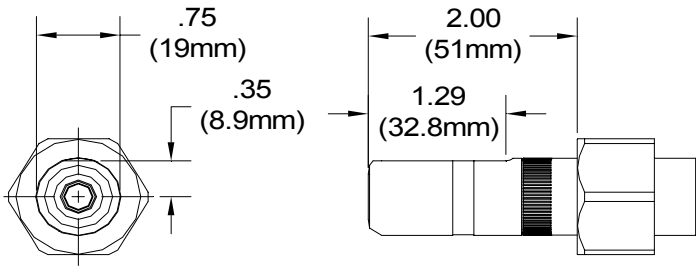

Use Hex-Key in rear of piston for nose assembly attachment.

Slots on retaining nut stop, supplied with tool, fit over ears on anvil assembly

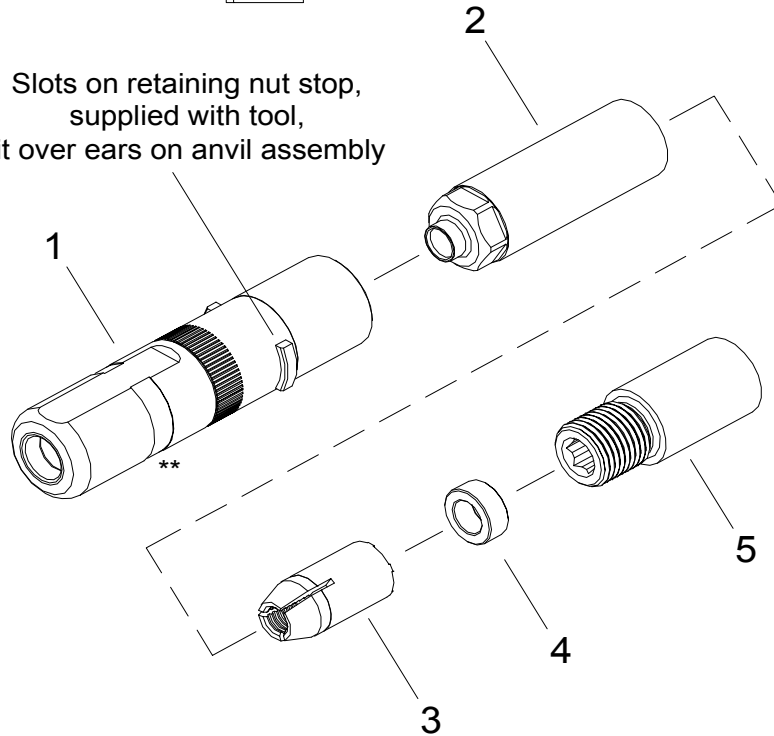

Rev. 4/06

*Anvil Assembly includes 35208 retainer
 **Yellow band designates nose assemblies for lightweight GP® fasteners.

GAGE BILT
 MADE IN U.S.A.

GAGE BILT PRODUCTS CORP.

14500 Barber Drive (586) 771-7664
 Warren, Mi 48088 (586) 771-2665 Fax
 e-mail:solutions@gagebilt.com / www.gagebilt.com

Type:		Fastener:	Recommended Tool: GBP730E
Non Self-Releasing 1/4" Ø		LGP® Lockbolts	
			Alternate Tools: GBP712C & GBP2400B
Ref. No.	Qty.	Description	LGP08-730B-20
1	1	Anvil	10891
2	1	Collet	20869
3	1	Super-Grip Jaw Assembly	30861-S2
4	1	Spacer	60832
5	1	Collet Extension	70835