

NOSE ASSEMBLY DATA SHEET

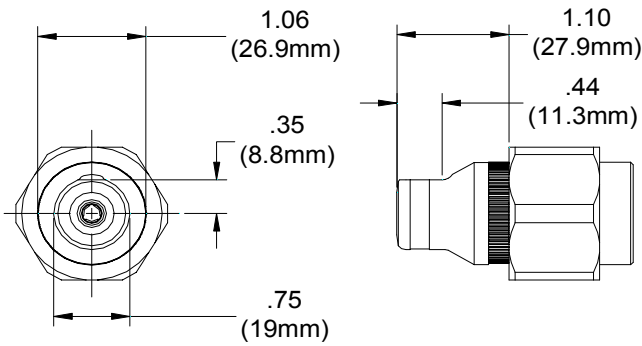

Use Hex-Key in rear of piston for nose assembly attachment.

Use Hex-Key in rear of collet extension for collet attachment.

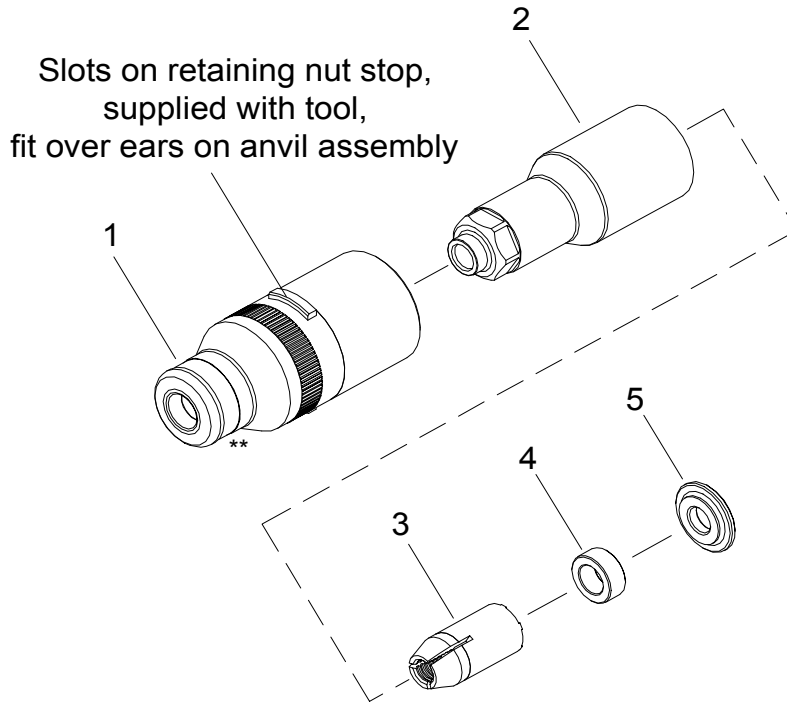

1/08

*Anvil Assembly includes 35308 retainer.

**Yellow band designates nose assemblies for lightweight GP® fasteners.

GAGE BILT

MADE IN U.S.A.

GAGE BILT Inc.

44766 Centre Court (586) 226-1500
 Clinton Twp. MI 48038 (586) 226-1505 Fax
 e-mail:solutions@gagebilt.com / www.gagebilt.com

Type:		Fasteners:	Recommended Tool: GB745
Non Self-Releasing 1/4" Ø		LGP® lockbolts	Alternate Tools: GBP4801B
Ref. No.	Qty.	Description	LGP08- 745B-12
1	1	Anvil	18805
2	1	Collet	20872
3	1	Super-Grip Jaw Assembly	30861-S2
4	1	Spacer	60832
5	1	Follower	40847