

NOSE ASSEMBLY DATA SHEET

Use Hex-Key in rear of piston for nose assembly attachment.

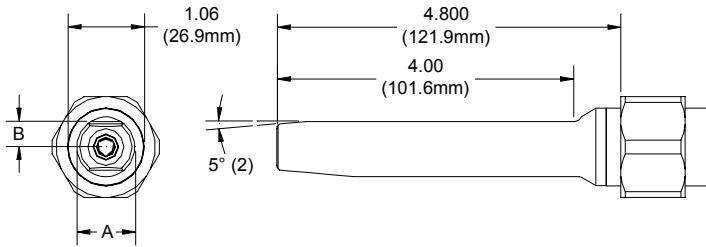

- A 05-.635 (16.1mm)
 06-.705 (17.9mm)
 08-.750 (19.1mm)
 10-.920 (23.4mm)
 12-1.060 (26.9mm)

- B 05-.290 (7.4mm)
 06-.320 (8.1mm)
 08-.350 (8.9mm)
 10-.431 (10.9mm)
 12-.475 (12.1mm)

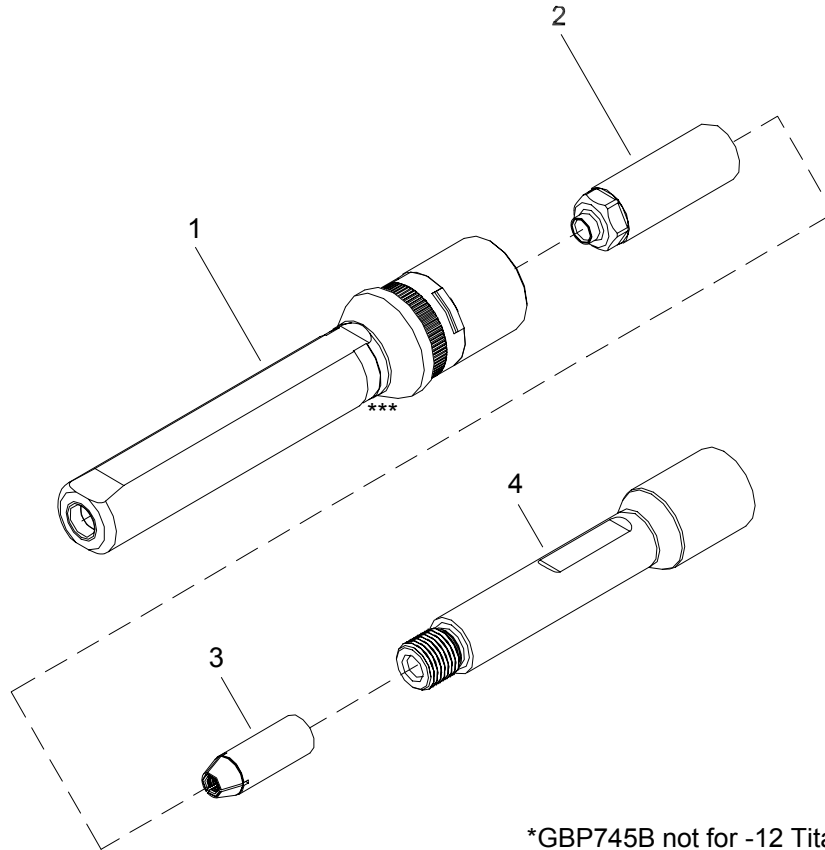

*GBP745B not for -12 Titanium Fasteners.

**Anvil Assembly includes 35308 retainer.

***Yellow band designates nose assemblies for lightweight GP® fasteners.

4/00

GAGE BILT

GAGE BILT PRODUCTS CORP.

14500 Barber Drive (586) 771-7664
 Warren, Mi 48088 (586) 771-2665 Fax
 e-mail:solutions@gagebilt.com / www.gagebilt.com

Type: Non Self-Releasing		Fastener:		Recommended Tool: *GBP745B Alternate Tools: GBP4801			
5/32, 3/16, 1/4, 5/16 & 3/8 Ø		LGP® Lockbolts					
Ref. No.	Qty.	Description	LGP05-745B-48CN	LGP06-745B-48CN	LGP08-745B-48CN	LGP10-745B-48CN	LGP12-745B-48CN
1	1	Anvil Assy.	10583	16617	18814	11027	11225-1
2	1	Collet	20537	20655	20869	21018	21225
3	1	Super Grip Jaw Assembly	30542-S	30651-S	30858-S	31022-S	31221-S
4	1	Collet Extension	70553	70638	70837	71021	71220