

NOSE ASSEMBLY DATA SHEET

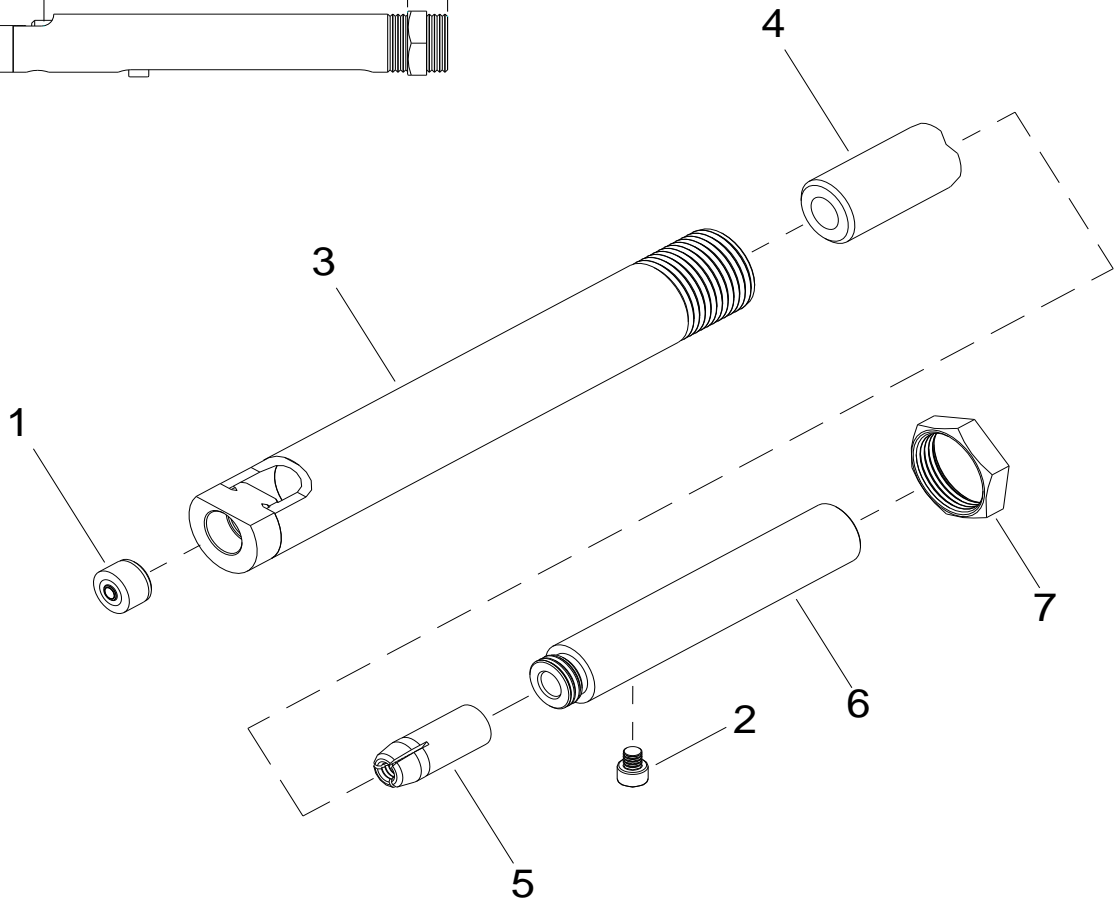
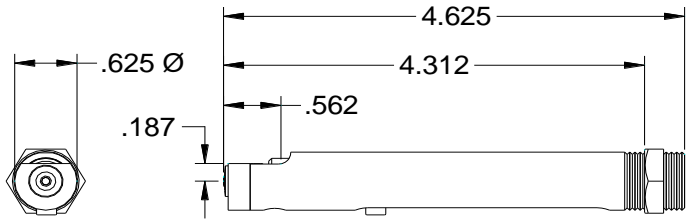

7/07 REV. 2/14

*Requires 730715 adapter.

**These tools for 3/16" Ø aluminum maximum.

GAGE BILT
MADE IN U.S.A.

GAGE BILT Inc.

44766 Centre Court (586) 226-1500
Clinton Twp., MI 48038 (586) 226-1505 Fax
e-mail:solutions@gagebilt.com / www.gagebilt.com

Type: Non Self-Releasing		Fasteners: MBC® NAS1719, NAS1720 & NAS1721	Recommended Tool: **GB715		
1/8", 5/32" & 3/16" Ø			Alternate Tools: **GB51 & *GB752		
Ref. No.	Qty.	Description	MBC04-715B-43	MBC05-715B-43	MBC06-715B-43
1	1	Anvil Insert	10259-1	10260-1	10261-1
2	1	Screw	70303	70303	70303
3	1	Anvil & Holder Assy (Incl. #1)	17781	17782	17783
4	1	Collet	20301	20301	20301
5	1	Maxi-Jaw Assy	30418-S1	30529-S	30633-S5
6	1	Drawbolt	70301	70301	70301
7	1	Locknut	70411	70411	70411