

# NOSE ASSEMBLY DATA SHEET

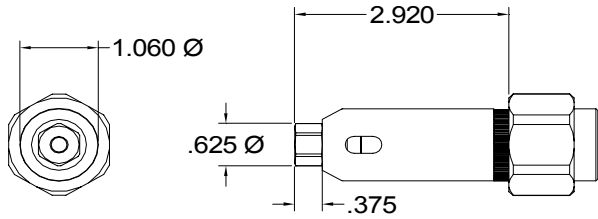

Use Hex-Key in rear of piston for nose assembly attachment.

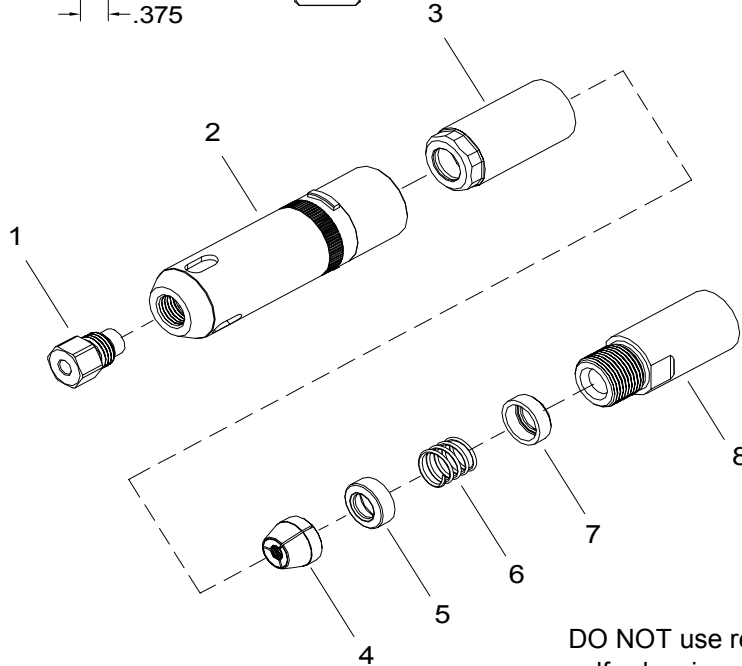

DO NOT use retaining nut stop for self-releasing nose assemblies.

\*Anvil Assembly includes 35308 retainer.



2/06

**GAGE BILT**  
MADE IN U.S.A.

**GAGE BILT Inc.**

44766 Centre Court (586) 226-1500  
Clinton Twp., MI 48038 (586) 226-1505 Fax  
e-mail:solutions@gagebilt.com / www.gagebilt.com

Type:		Fastener:	Recommended Tool:
Self-Releasing 5/16" Ø		Magna-Lok®	GB745
			Alternate Tools: GBP4801(A) & GBP4804(A)
Ref. No.	Qty.	Description	MGL10-353-28
1	1	Anvil Insert	10195
2	1	Anvil Assembly	11150
3	1	Collet	21236
4	1	Jaw Set	31026
5	1	Follower	41219
6	1	Spring	51220
7	1	Locator	61212
8	1	Collet Extension	71219