

NOSE ASSEMBLY DATA SHEET

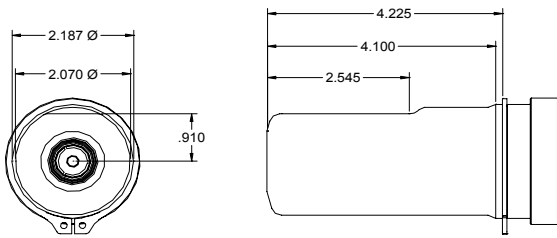

1. Ensure Piston is in full forward position.
2. Disconnect tool control cord.
3. Screw assembled Collet onto Piston until top of collet flat lines up with Adapter face of tool.
4. If Collet Lock (11) is not in Piston groove, continue to turn 1/4 turn, or less until lock engages groove.
5. Tighten Set Screw (12) on (new noses).
6. Slide Anvil (1) over assembled Collet. Install Split Ring, Sleeve (furnished with tool) and Retaining Ring (13).

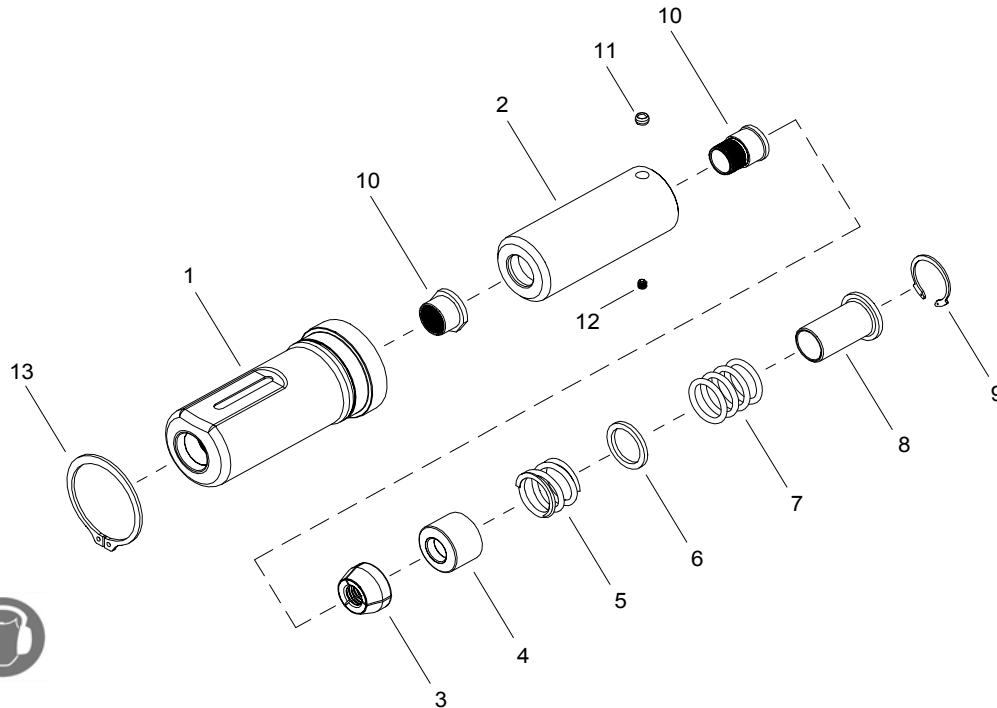

Rev. 5/07

GAGE BILT
MADE IN U.S.A.

GAGE BILT PRODUCTS CORP.

14500 Barber Drive
Warren, Mi 48088

(586) 771-7664
(586) 771-2665 Fax

e-mail:solutions@gagebilt.com / www.gagebilt.com

Type:		Fastener:	Recommended Tool:
Self-Releasing 5/8" Ø		C50L	GBP585
			Alternate Tools: Model 585 or Model 586
Ref. No.	Qty.	Description	20-585-41
1	1	Anvil Assembly	12001
2	1	Collet Assembly (Inc. 10,11 & 12)	22000
3	1	Jaw Set	32001
4	1	Follower	42003
5	1	Spring	52001
6	1	Spacer	55020
7	4	O'Ring	400846
8	1	Sleeve	62006
9	1	Retaining Ring	402263
10	1	Release & Ejector Kit	82000
11	1	Collet Lock	54502
12	1	Socket Set Screw	A-280
13	1	Retaining Ring	401027
14	1	Collet Assembly (Inc. 2 thru 12)	92000