

NOSE ASSEMBLY DATA SHEET

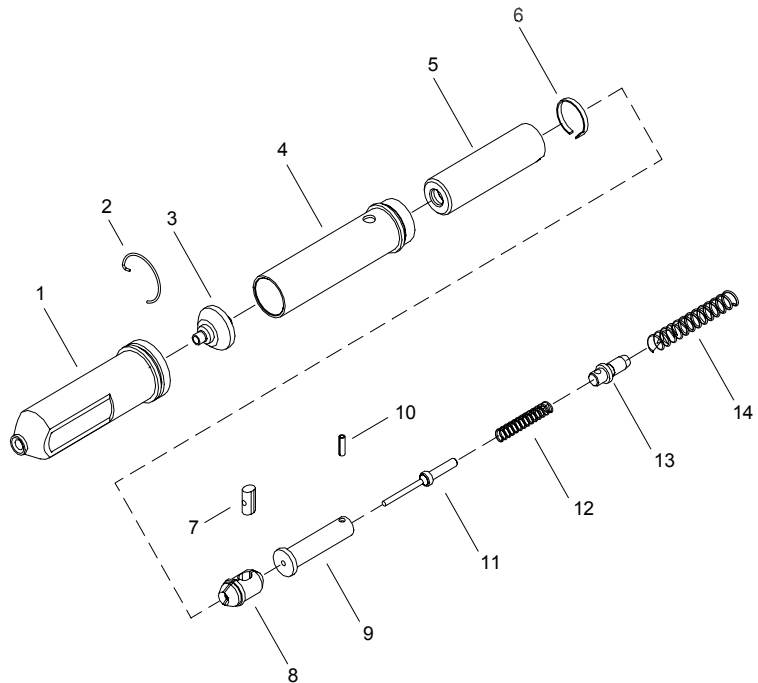
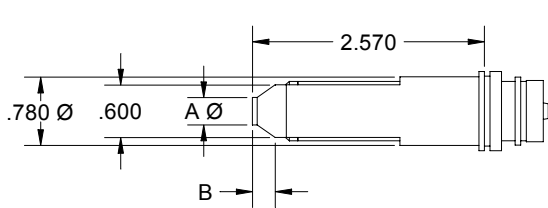

Countersunk nose assemblies may be used for installing both universal and countersunk rivets. Universal style nose assemblies are being obsoleted and countersunk nose assemblies will be shipped as an acceptable equivalent.

Rev. 12/04

GAGE BILT PRODUCTS CORP.

GAGE BILT

14500 Barber Drive (586) 771-7664
 Warren, Mi 48088 (586) 771-2665 Fax
 e-mail: solutions@gagebilt.com / www.gagebilt.com

Type: Non Self-Releasing	Fastener:	Recommended Tool:
3/32, 1/8, 5/32, 3/16 & 1/4 Ø	CHERRYLOCK®	GBP784

Ref. No.	Qty.	Description	3-681-25	4-681-25	5-681-25	6-681-25	8-681-25
1A	1	"U" Outer Sleeve - Universal	10339	10415	10527	10646	10864
1B	1	"C" Outer Sleeve - Countersunk (MS 20426)	10341	10416	10528	10647	10865
1C	1	"US" Outer Sleeve - Uni-Sink	-----	10419	10531	10650	-----
1D	1	"F" Outer Sleeve - Countersunk (156°)	-----	10417	10529	16696	-----
1E	1	"S" Outer Sleeve - Countersunk (NAS 1097)	-----	10418	10530	10648	-----
2	1	Retainer	50501	50501	50501	50501	50501
3	1	Anvil	19301	19403	19504	19604	19802
4	1	Tube	40507	40507	40507	40507	40507
5	1	Collet	20512	20512	20512	20512	20512
6	1	Collet Lock	50502	50502	50502	50502	50502
7	1	Stem Stop	70313	70401	70510	70510	70510
8	1	Jaws	30306	30407	30512	30611	30812
9	1	Pusher	70402	70402	70403	70403	70403
10	1	Roll Pin	402130	402130	402130	402130	402130
11	1	Ejector Pin	70404	70405	70406	70406	70406
12	1	Spring	50503	50503	50504	50504	50504
13	1	Stop	70407	70407	70407	70407	70407
14	1	Spring	50506	50506	50506	50506	50506

CHERRYLOCK® is a registered trademark of Avdel / Cherry Textron.

681 NOSE ASSEMBLIES

FOR 2000 SERIES CHERRYLOCK® RIVETS
CONFORMING TO NAS 1400 & NAS 1740

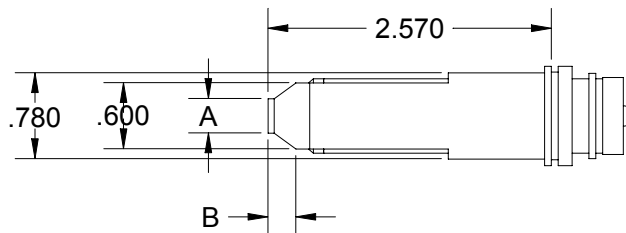

RIVET DIAMETER	NOSE ASSEMBLY	DIMENSION	
		A	B
3/32"	3U-681-25	.188	.348
3/32"	3C-681-25	.163	.332
1/8"	4U-681-25	.250	.341
1/8"	4C-681-25	.208	.377
5/32"	5U-681-25	.313	.377
5/32"	5C-681-25	.269	.352
3/16"	6U-681-25	.375	.418
3/16"	6C-681-25	.335	.386
1/4"	8U-681-25	.500	.452
1/4"	8C-681-25	.458	.398

INSTALLING 681 NOSE ASSEMBLY ON TOOL

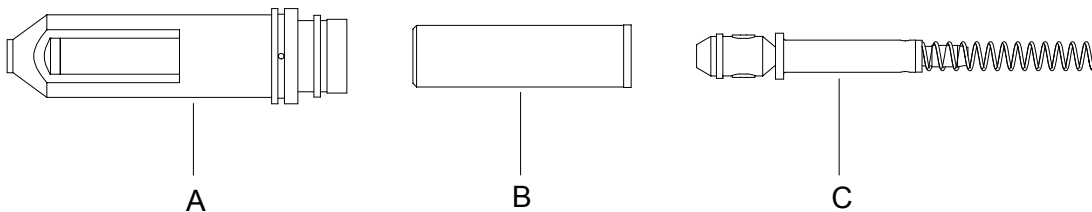

1. Remove knurled cap from front of riveter head
2. Place jaw assembly (C) inside collet (B).
3. Insert spring end of jaw assembly into hole in head piston. Apply enough pressure to engage collet threads. Turn until collet bottoms on shoulder of piston and collet lock snaps into slot in piston. Hand tight is sufficient.
4. Place sleeve assembly (A) over collet and head piston. Slip knurled cap over the sleeve assembly and hand tighten onto end of riveter head.

MAINTENANCE AND REPAIR

Make sure the nose assembly is kept clean, especially around the riveting end, adhesives, chips, sealants, etc., will clog the serrations of the jaws and cause slippage. The top of the lock ring anvil must be kept clean. Foreign materials can build up and keep it from going all the way forward to set the locking ring in the rivet.

To replace ejector pin (11) or ejector spring (12) it is necessary to first remove roll pin (10) and stop (13).

Note: To remove collet, push collet lock back into collet (using a blunt pointed tool) turning the collet counter clockwise.

Length of anvil (3) is critical and must meet tolerances indicated in sketch. If anvil is too short it should be replaced. If anvil protrudes more than .004 then the outer sleeve (1) is worn and must be replaced.

