

353204 ADAPTER DATA SHEET

To attach adapter and nose to tool:

1. Remove nose assembly nut from nose drawbar.
2. Place adapter nut (3) into threaded end of collet with thread forward as shown. Thread collet adapter (2) onto head piston.
3. With collet placed in nose assembly anvil, tighten both onto anvil adapter assembly (1).
4. Slide anvil adapter (1) over collet adapter (2) and lock into place on tool. Slide drawbar into nose assembly thru adapter assembly.
5. Using tee-wrench (4) thru rear of installation tool and 1/4" allen wrench on front of nose assembly drawbar tighten nut to drawbar.

CAUTION

Pintail may eject forcibly.
Used for closed access applications only to prevent sever personal injury!

To remove adapter and nose from tool
reverse assembly instructions

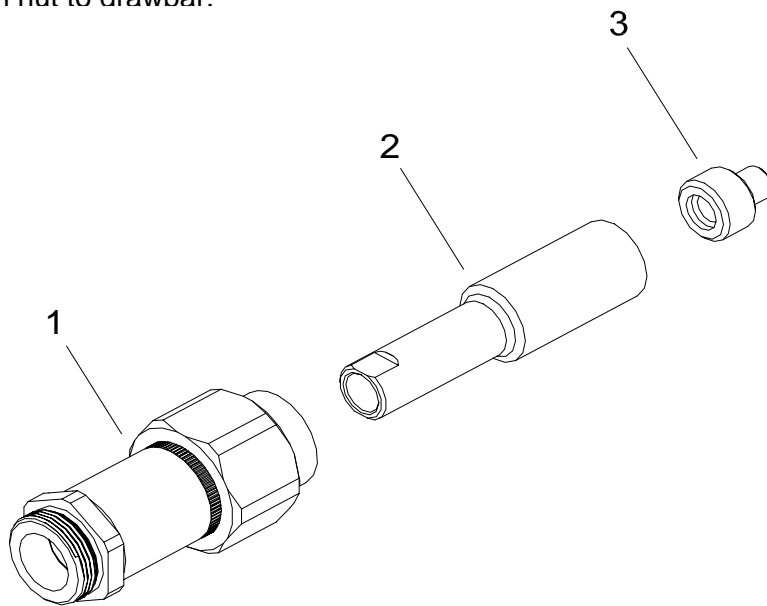

1/94 Rev. 11/01

*Must use 480152 stroke limiter with GBP4801.

GAGE BILT

GAGE BILT PRODUCTS CORP.

14500 Barber Drive (586) 771-7664
Warren, Mi 48088 (586) 771-2665 Fax
e-mail:solutions@gagebilt.com / www.gagebilt.com

Type:

Rotatable
Offset Nose Assembly
Adapter

Adapts GBP204 Series Nose Assemblies to:
GBP745B and GBP4801 Installation Tools

Ref. No.	Qty.	Description	353204
1	1	Anvil Adapter Assembly	353223
2	1	Collet Adapter	353221
3	1	Nut	353222
4	1	Tee-Wrench	A-133