

NOSE ASSEMBLY DATA SHEET

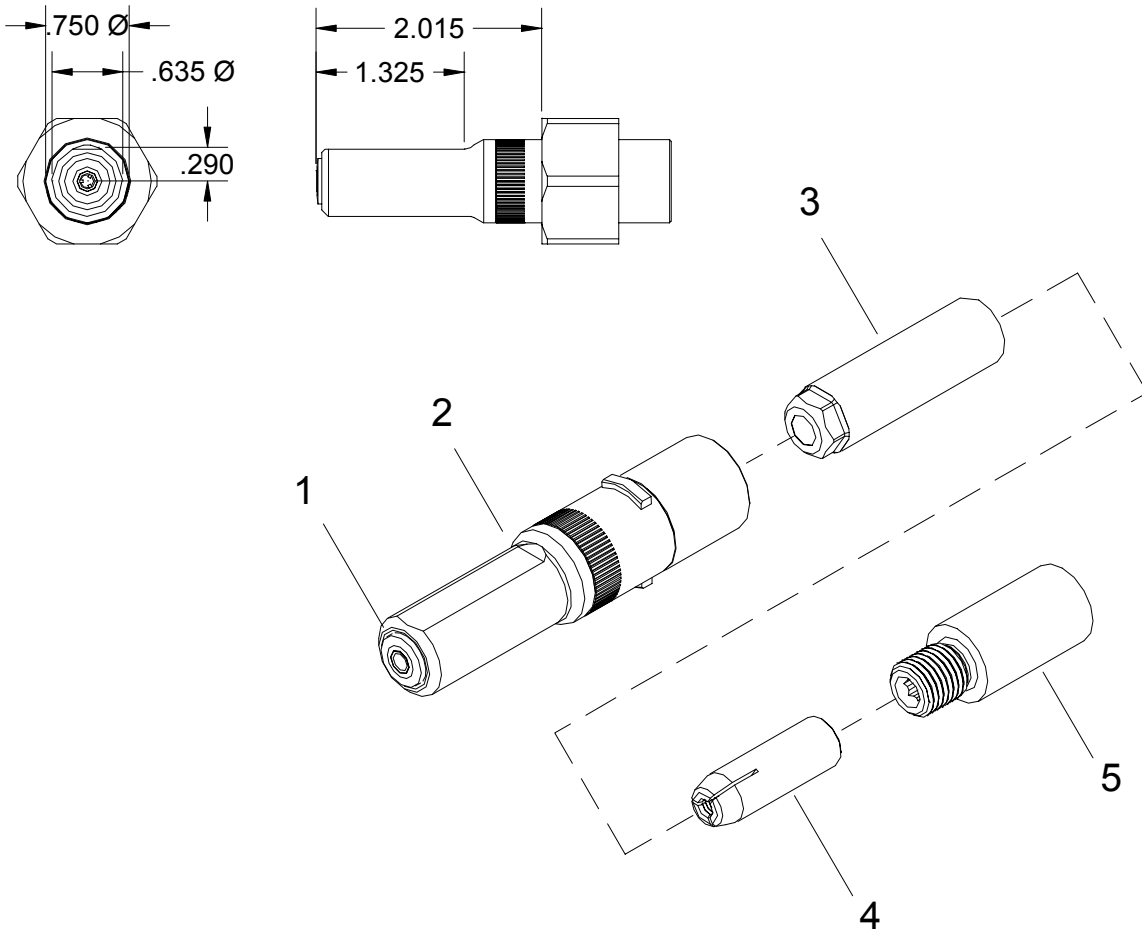

Use Hex-Key in rear of piston for nose assembly attachment.

Use Hex-Key in rear of collet extension for collet disassembly.

11/01

*Anvil Assembly consists of #1 and 35208 retainer.

GAGE BILT

GAGE BILT PRODUCTS CORP.

14500 Barber Drive

(586) 771-7664

Warren, Mi 48088

(586) 771-2665 Fax

e-mail: solutions@gagebilt.com / www.gagebilt.com

Type:		Fastener:		Recommended Tool:	
Non Self-Releasing 1/8, 5/32 & 3/16 \varnothing		NAS1398A/1399A RV1000/1100 & 1200		GBP752B	
				Alternate Tools: GBP703B/352 & GBP2400B	
Ref. No.	Qty.	Description	4A-752B-20	5A-752B-20	6A-752B-20
1	1	Anvil-Driving	10427	10560	10657
2	1	Anvil & Holder Assy.	17760	17761	17762
2a	1	(Includes #1)			
3	1	Collet	20717	20717	20717
4	1	Super-Grip Jaw Assembly	30425-S	30545-S	30656-S
5	1	Collet Extension	70550	70550	70550