

NOSE ASSEMBLY DATA SHEET

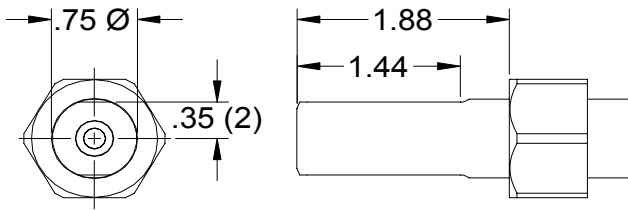

Use Hex-Key in rear of piston for nose assembly attachment.

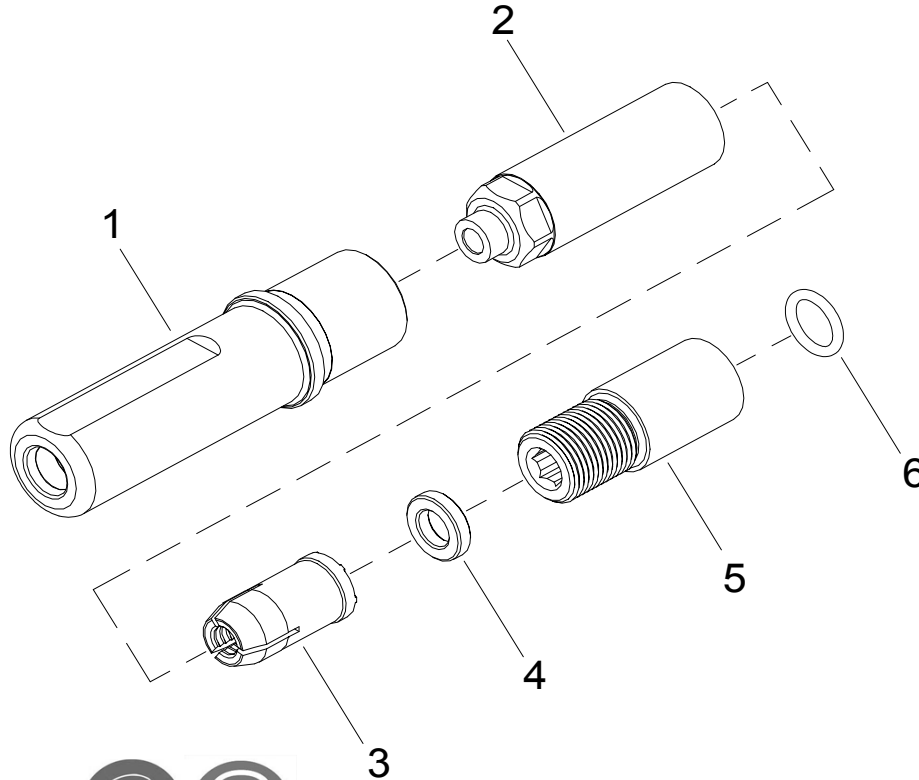

6/01 Rev. 11/06

*Requires 100 PSI.

GAGE BILT
MADE IN U.S.A.

GAGE BILT Inc.

44766 Centre Court (586) 226-1500
Clinton Twp. MI 48038 (586) 226-1505 Fax
e-mail:solutions@gagebilt.com / www.gagebilt.com

Type:		Fastener:	Recommended Tool:
Non Self-Releasing 1/4" Ø		BOM®-R08	*GB731
			Alternate Tools: GB2480
Ref. No.	Qty.	Description	BOM08-713-20
1	1	Anvil	18854
2	1	Collet	20825-1
3	1	Super Grip Jaw Assembly	30653-S
4	1	Spacer	40676
5	1	Collet Extension	70823
6	1	O' Ring	400778