

NOSE ASSEMBLY DATA SHEET

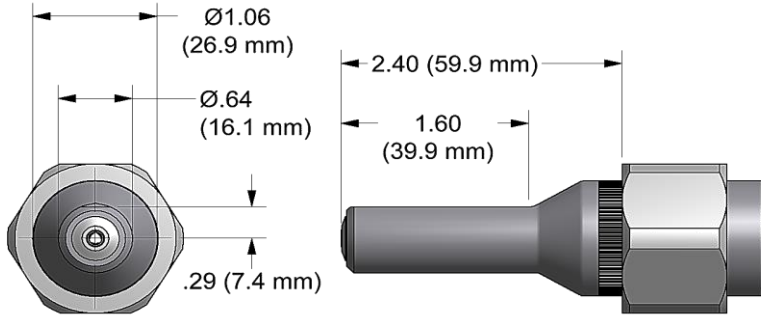

SLOTS ON RETAINING NUT STOP, SUPPLIED WITH TOOL, FIT OVER EARS ON ANVIL ASSY

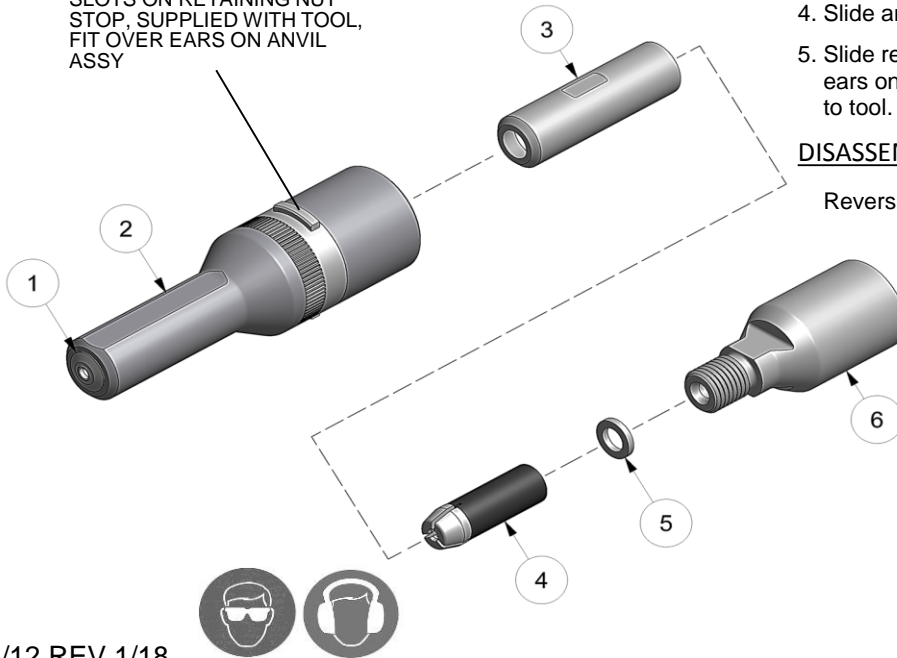

ASSEMBLY:

Note: If nose assy is assembled as it is when purchased new, follow steps 3-5 to attach to tool.

1. Insert super grip jaw assy (4) into rear of collet (3). Place spacer (5) on rear of super grip jaw assy (4) (Note direction in exploded view).
2. Thread collet (3) to extension-collet (6) using hex key in front of collet-extension (6) and flats provided on collet (3).
3. Thread assembled collet (3) and extension-collet (6) onto piston of tool using flats provided and hex in rear of piston.
4. Slide anvil & holder assy (2) over collet (3).
5. Slide retaining nut stop and retaining nut over ears on anvil (see exploded view) and tighten to tool.

DISASSEMBLY:

Reverse assembly instructions.

1/12 REV 1/18



GAGE BILT
MADE in USA

44766 Centre Court Clinton Twp. MI 48038 USA
Ph: +1 (586) 226-1500 Fax: +1 (586) 226-1505
solutions@gagebilt.com / www.gagebilt.com

Type:		Fastener:	Recommended Tool: GB745
Non Self-Releasing 1/8" Ø		NAS1398A/NAS1399A RV1000/RV1100 & RV1200	Alternate Tools: GB756 & GB2581(A)
Ref. No.	Qty.	Description	4A-745C-23
1	1	Anvil Insert	10488
2	1	Anvil Assy (Inc. #1)	13302
3	1	Collet	20727
4	1	Super-Grip Jaw Assy	30425-CS
5	1	Spacer	70572
6	1	Extension-Collet	70552