

NOSE ASSEMBLY DATA SHEET

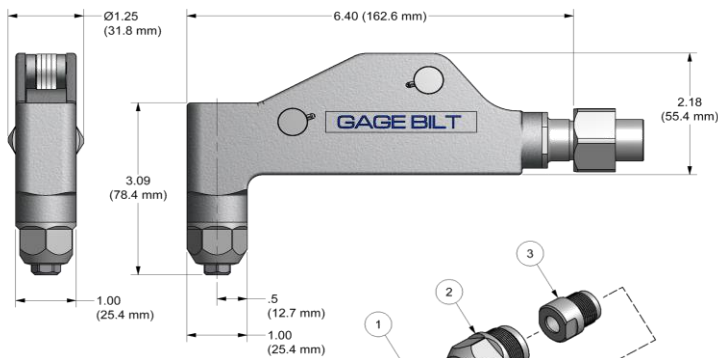

WHEN MOUNTING ON RIVETER:
Press & Hold lever (10) in

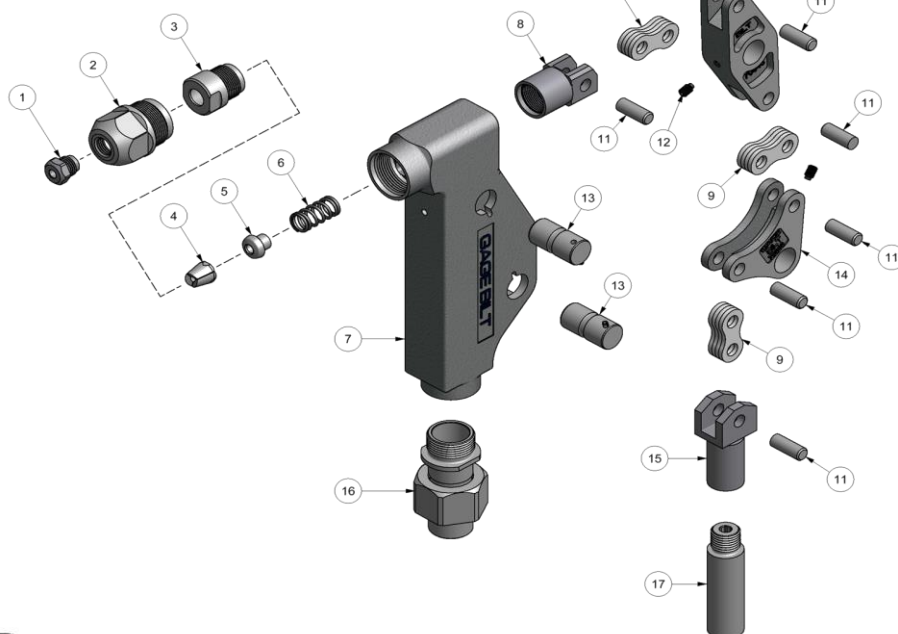

Rev. 8/17

GAGE BILT
MADE in USA

44766 Centre Court Clinton Twp. MI 48038 USA
Ph: +1 (586) 226-1500 Fax: +1 (586) 226-1505
solutions@gagebilt.com / www.gagebilt.com

Type:	Fasteners:	Recommended Tool: GB713
Single Action 1/4" Ø	OPEN END NAIL RIVET	

Ref. No.	Qty.	Description	8N-713A-58RA
1	1	Nose Tip	10211-5
2	1	Holder	13424
3	1	Collet	28837
4	1	Jaw Set	30856-1
5	1	Follower	48808-3
6	1	Spring	A-1492
7	1	Frame	70864
8	1	Collet Bolt	70839-1
9	12	Link	70841
10	1	Lever	70843
11	6	Link Pin	70842
12	2	Set Screw	70844
13	2	Pivot Pin Assy	70845
14	1	Bellcrank	70846
15	1	Drawbolt	70847
16	1	Anvil Adapter Assy	70868
17	1	Extension-Collet	70875

MOUNTING INSTRUCTIONS

Attach riveter to air source for correct piston positioning. Push the drawbolt assembly forward (see above), before mounting. While holding drawbolt in a forward position, thread the nose assembly onto the riveter, making sure that both internal and external threads are connected. Use the jam-nut to lock the pulling head in position. Cycle the tool to make sure it is functional.

DISASSEMBLY AND ASSEMBLY

Disassembly:

Loosen and remove holder (2) from frame (7). Unscrew collet (3) which contains jaws (4), follower (5) and spring (6) from collet bolt (8).

Remove 2 set screws (12) and push out 2 pivot pins (13) to permit removal of linkage. Remove link pin (11) from collet bolt (8) and links (9) to disengage from lever (10).

Remove 5 link pins (11) to disassemble lever (10), links (9), bell crank (14) and drawbolt (15).

Reassembly:

Reverse the procedure. Linkage, consisting of lever (10), links (9), bell crank (14) and drawbolt (15) should be assembled as a subassembly before inserting lever (10) into collet bolt (8). Apply VIBRA-TITE® to set screws (12) when reassembling linkage. MAKE SURE NOTCHES ON COLLET BOLT (8) ARE POINTING TOWARDS LEVER (10). This complete subassembly may then be inserted into frame (7) and retained by pivot pins (13). Apply Loctite® 242 to threads on Anvil Adapter Ass'y (16) and Extension-Collet (17) during reassembly.