

# NOSE ASSEMBLY DATA SHEET

**CAUTION:**  
Pintail may eject forcibly. Use for closed access applications only to prevent SEVERE PERSONAL INJURY!!

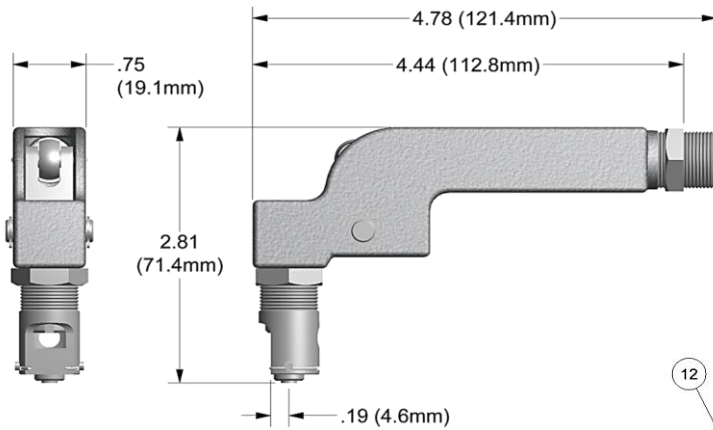

### Attachment Instructions

Using your index finger press the 70309 closier cap completely down into the nose assembly. While continuing to hold the closier cap down, thread the nose assembly completely onto tool. Position nose assembly to the desired position and lock in place using 70411 locknut.

- Consult Gage Bilt for all other alternative tool options.

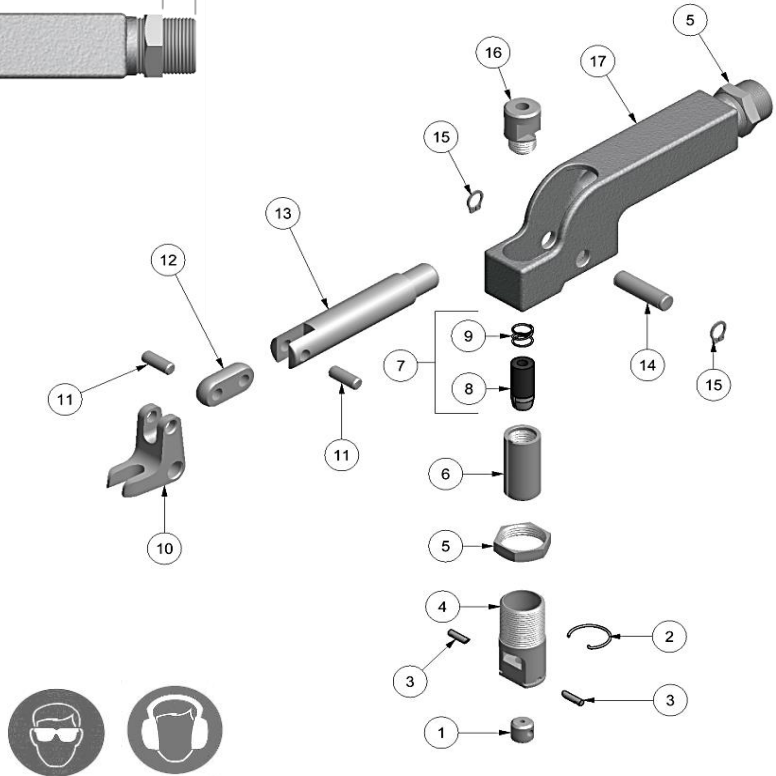

8/06 Rev. 6/14

Covered Under Patent No. 5,029,881

\*Use 3/16 Ø Self-Plugging aluminum maximum

**GAGE BILT**  
MADE IN U.S.A.

**GAGE BILT Inc.**

44766 Centre Court (586) 226-1500  
Clinton Twp. MI 48038 (586) 226-1505 Fax  
e-mail:solutions@gagebilt.com / www.gagebilt.com

Type: Single Action Non Self-Releasing	Fastener: NAS1398A / NAS1399A NAS1738A / NAS1739A RV1000/1100 & 1200	Recommended Tool: *GB715
3/32, 1/8, 5/32 & 3/16 Ø		Alternate Tools: *GB51

Ref. No.	Qty.	Description	3A-715B-44RA	4A-715B-44RA	5A-715B-44RA	6A-715B-44RA
1	1	Insert	10303	10304	10305	10306
2	1	Spring-Ratchet Pin	50302	50302	50302	50302
3	2	Pin-Ratchet	15504	15503	15501	15502
4	1	Housing-Nose	10335	10335	10335	10335
5	2	Locknut	70411	70411	70411	70411
6	1	Collet	20401	20401	20401	20401
7	1	Jaw Ass'y (Inc. 8 & 9)	30314-A2	30418-A1	30529-A1	30633-A1
8	1	Super Grip Jaw Assy	30314-S11	30418-S6	30529-S5	30633-S14
9	1	Spring	50306	50306	50306	50306
10	1	Pivot	70304	70304	70304	70304
11	2	Link Pin	70305	70305	70305	70305
12	1	Link Pin	70306	70306	70306	70306
13	1	Drawbolt	70307	70307	70307	70307
14	1	Pivot Pin	70308	70308	70308	70308
15	2	Retaining Ring	400987	400987	400987	400987
16	1	Closier Cap	70309	70309	70309	70309
17	1	Housing	10338	10338	10338	10338