

# NOSE ASSEMBLY DATA SHEET

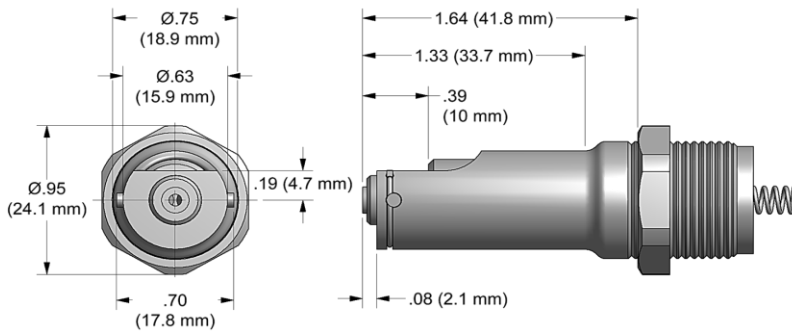

## ASSEMBLY:

**Note:** If nose assy is assembled as it is when purchased new, follow steps 5-6 to attach to tool.

1. Insert super grip jaw assy (6) into collet (5).
2. Drop spring (8) in collet (5) flush against rear of super grip jaw assy (6) and set aside.
3. Place anvil-insert (1) in anvil holder (4) aligning holes in anvil-insert (1) with holes in anvil holder (4). See exploded view for reference.
4. Place ratchet pins (3) into the anvil holder (4) holes provided leaving enough room to install retaining ring (2) into groove on anvil holder (4) and into ratchet pin (3) groove. Squeeze ratchet pins (3) into anvil holder (4).
5. Tighten assembled collet (5) to piston on tool using flats provided.
6. Slide anvil holder (4) over assembled collet (5) and tighten locknut (7) to tool.

## DISASSEMBLY:

Reverse assembly instructions.

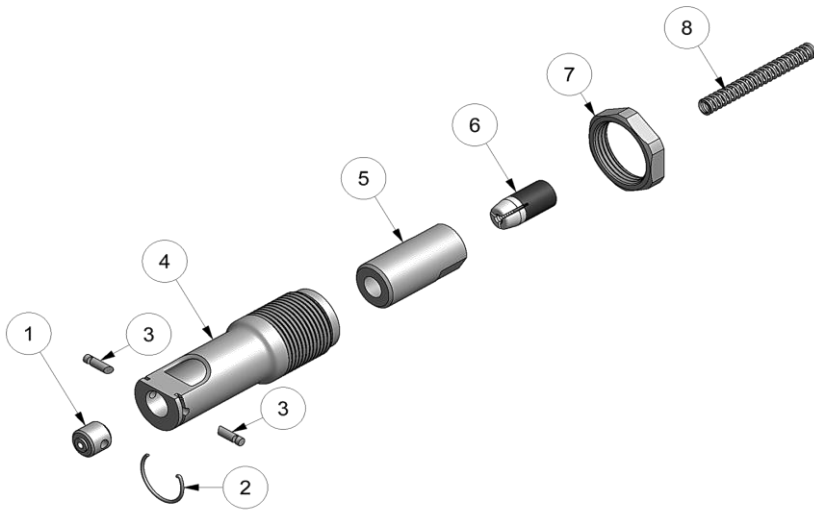

REV 6/18

# GAGE BILT

44766 Centre Court Clinton Twp. MI 48038 USA  
 Ph: +1 (586) 226-1500 Fax: +1 (586) 226-1505  
 solutions@gagebilt.com / www.gagebilt.com

Type: Single Action Non Self-Releasing		Fasteners: NUT PLATE RIVETS MS20600 SERIES CCR224/264/274 MS/9SP/PT BACR15CC/CF/DA/DR		Recommended Tool: GB704		
3/32", 1/8", 5/32" & 3/16" Ø						
Ref. No.	Qty.	Description	3C-704A-16	4C-704A-16	5C-704A-16	6C-704A-16
1	1	Anvil Insert	10383	10384	10385	10386
2	1	Ratchet Pin Spring	50302	50302	50302	50302
3	2	Ratchet Pin	15504	15503	15501	15501
4	1	Anvil Holder	13461	13461	13461	13461
5	1	Collet	20334	20334	20334	20334
6	1	Super Grip Jaw Assy	30314-S10	30418-S2	30529-S1	30633-S3
7	1	Nut	70104	70104	70104	70104
8	1	Spring	70109	70109	A-1495	A-1495