

NOSE ASSEMBLY DATA SHEET

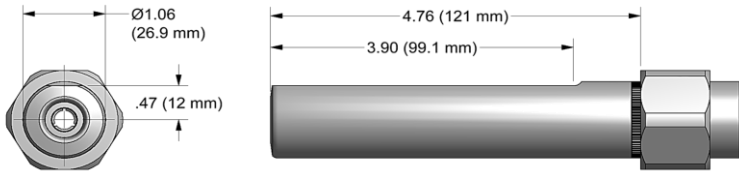

ASSEMBLY:

Note: If nose assy is assembled as it is when purchased new, follow steps 3-5 to attach to tool.

1. Insert super grip jaw assy (3) into rear of collet (2). (Note direction in exploded view).
2. Thread collet (2) to extension-collet (4) using flats provided.
3. Thread assembled collet (2) and extension-collet (4) onto piston of tool using flats provided and hex in rear of piston.
4. Slide anvil assy (1) over collet (2).
5. Slide retaining nut stop and retaining nut over ears on anvil (see exploded view) and tighten to tool.

SLOTS ON RETAINING NUT STOP, SUPPLIED WITH TOOL, FIT OVER EARS ON ANVIL ASSY

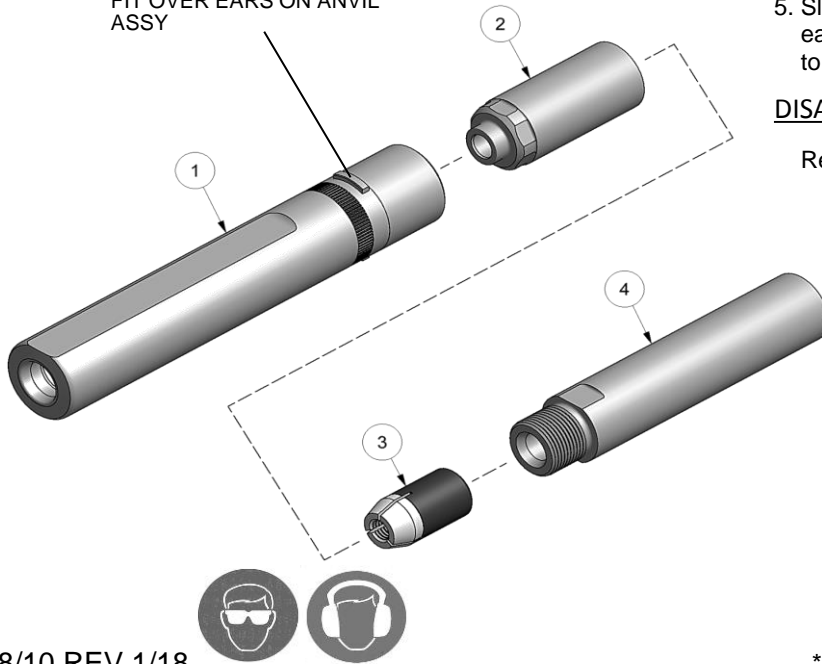

DISASSEMBLY:

Reverse assembly instructions.

8/10 REV 1/18

*Anvil Assembly includes 35308 retainer.

GAGE BILT
MADE in USA

44766 Centre Court Clinton Twp. MI 48038 USA
Ph: +1 (586) 226-1500 Fax: +1 (586) 226-1505
solutions@gagebilt.com / www.gagebilt.com

Type:		Fastener:	Recommended Tool: GB756
Non Self-Releasing 3/8 Ø		OSR-12	Alternate Tools: GB2581(A)
Ref. No.	Qty.	Description	OS12-756A-48
1	1	*Anvil Assy	11238
2	1	Collet	21247
3	1	Super Grip Jaw Assy	31028-S2
4	1	Extension-Collet	71220